

455 nominal diameter vented screw lid

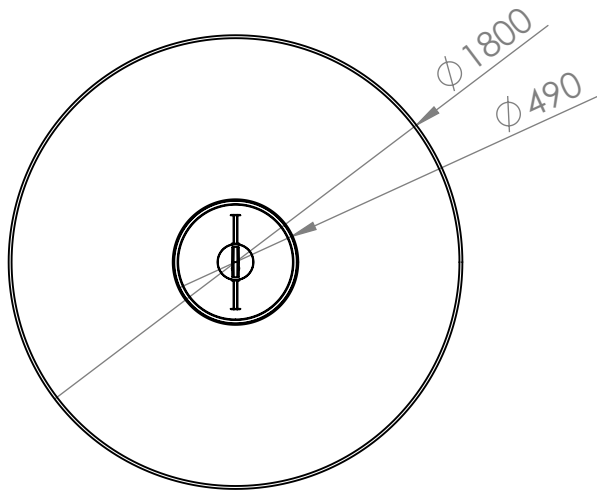
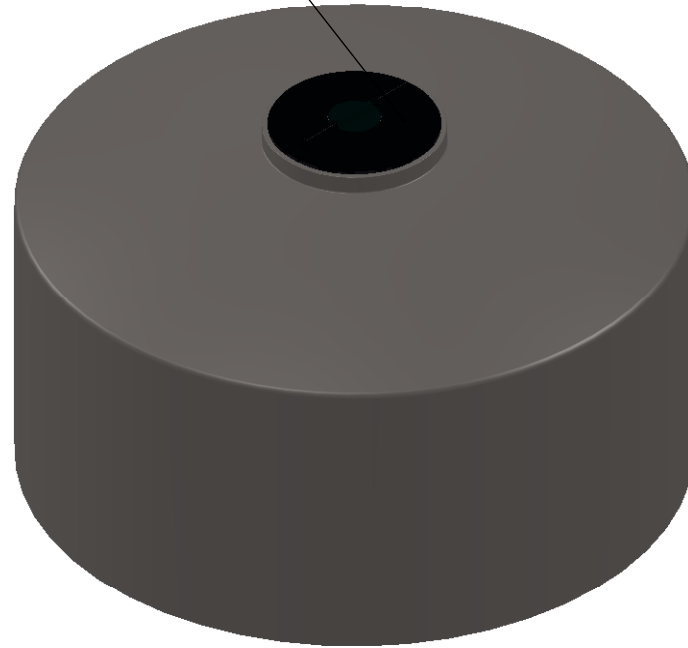

Thursday, 8 December 2011 11:30:16 AM

	NAME	SIGNATURE	DRAWN DATE	21/11/2011	Rota Moulding Ph 92501125	
DRAWN	WF		REVISION	-		
CHK'D			REVISION DATE	-	2400ltr Cone Bottom Tank	
APPV'D			Material	LLDPE		
MFG			WEIGHT	-	TITLE:	
Q.A			RM Code	SP2400CB	DWG NO.	
				UNLESS OTHERWISE SPECIFIED: DIMENSIONS ARE IN MILLIMETERS		
There is a possibility of a + or -1% dimensional variation in rotational moulded Plastic products				DEBUR AND BREAK SHARP EDGES	SCALE 1:30 DO NOT SCALE DRAWING	SHEET 1 OF 1

A4